

# Product datasheet

## Vertical lifting fabric door

### ASSA ABLOY VL3116

**ASSA ABLOY**  
Entrance Systems

Experience a safer  
and more open world



# Copyright and Disclaimer Notice

Although the contents of this publication have been compiled with the greatest possible care, ASSA ABLOY cannot accept liability for any damage that might arise from errors or omissions in this publication. We also reserve the right to make appropriate technical modifications/replacements without prior notice.

No rights can be derived from the contents of this document.

Color guides: Color differences may occur due to different printing and publication methods.

ASSA ABLOY as word and logo are trademarks belonging to the ASSA ABLOY Group.

No part of this publication may be copied or published by means of scanning, printing, photocopying, microfilm or any other process whatsoever without prior permission in writing by ASSA ABLOY.

© ASSA ABLOY 2006-2024.

All rights reserved.

# Technical facts

## Features

Max size: (W / H)*	14000 x 16000 mm
Door leaf thickness:	160 mm
Fabric types:	Standard: Polyester (coating: plasticised PVC) Options: Sound reduction, heat resistant, security
Color:	8 standard colours
Guide rails material:	Aluminium
Windows:	Vision panels (width 800 mm standard)
Seals:	Bottom, side and top seal
Operation:	Standard: Electrical operator Optional: Automated operation, Access control, Safety functions

\* Other sizes may be available on request

## Performance

Operating speed:	0.2 - 0.3 m/sec
Wind load resistance*: (differential pressure)	0.45-1.6 kPa, depending on size (class 2 - 5, EN 12424)
Wind speed, door in motion:	< 20 m/s
Sound reduction (standard):	15 dB Rw (ISO 717)
Water resistance:	0.11 kPa (for a closed door) (class 3, EN 12425)
Air permeability:	12m <sup>3</sup> /(m <sup>2</sup> ·h) (class 2, EN 12426)
Operating environment temperature range:	-35 °C to +70 °C

\* Higher wind loads on request.

# Contents

Copyright and Disclaimer Notice.....	2
Technical facts.....	3
<b>1 Description.....</b>	<b>5</b>
1.1 General.....	5
1.1.1 Standard.....	5
1.1.2 Options.....	5
1.2 Door leaf.....	6
1.2.1 Construction.....	6
1.2.2 Intermediate section.....	6
1.2.3 Bottom section.....	6
1.2.4 Safety arresters.....	6
1.2.5 Material.....	7
1.2.6 Colors.....	7
1.2.7 Options.....	7
1.3 Guide rails.....	8
1.3.1 Jambs.....	8
1.3.2 Wind deflectors.....	9
1.4 Header box.....	10
1.4.1 Header box options.....	10
1.4.2 Header box - self-supporting version.....	10
1.5 Operating system.....	11
1.5.1 Electrical operation.....	11
1.5.2 Belt system.....	11
1.5.3 Gear motor.....	11
1.5.4 Control unit.....	11
1.5.5 Safety edge.....	12
1.5.6 Access and automation.....	12
<b>2 Specifications.....</b>	<b>15</b>
2.1 Clear width and clear height.....	15
2.2 Environmental tolerance.....	15
2.3 Surface treatment.....	15
2.4 Door leaf.....	16
2.4.1 Fabric data.....	16
2.5 Operating system.....	20
2.5.1 General specifications.....	20
<b>3 CEN Performance.....</b>	<b>21</b>
3.1 Lifetime expectation.....	21
3.2 Resistance to wind load.....	21
3.3 Resistance to water penetration.....	21
3.4 Air permeability.....	21
3.5 Thermal transmittance.....	22
3.6 Acoustic insulation.....	22
3.7 Operating forces and safe openings.....	22
<b>4 Building and space requirements.....</b>	<b>23</b>
4.1 Building preparations.....	23
4.1.1 Installation of the header box.....	23
4.1.2 Installation of the guide rails.....	25
4.1.3 Installation of the control unit.....	26
4.2 Space requirements.....	26
4.2.1 Space requirements for operation.....	27
4.2.2 Space requirements for control unit.....	27
4.2.3 Space requirements for maintenance.....	28
4.2.4 Space requirements - Installation against wall.....	29
4.2.5 Space requirements - Installation in door opening.....	30
4.2.6 Space requirements - Installation with self-supporting header box.....	31
<b>5 Service tailored to your needs.....</b>	<b>32</b>
Index.....	33

# 1 Description

## 1.1 General

The ASSA ABLOY VL3116 vertical lifting fabric door is especially designed for extreme industrial environments where doors are exposed to moisture, dust and very high or low temperatures, or where the door opening is large.

The unique design and structure offers durability, tightness, energy efficiency, operational reliability and minimum maintenance. Every door is individually designed to meet application requirements, for example wind load.

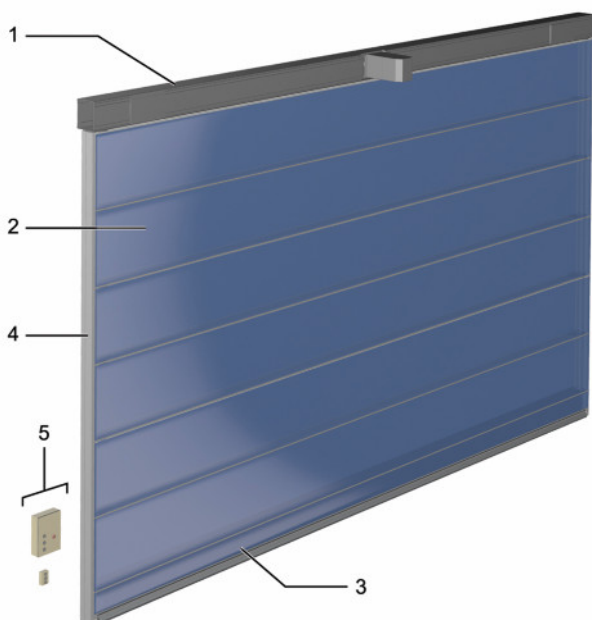

The ASSA ABLOY VL3116 vertical lifting fabric door has five main components:

1. Header box
2. Door leaf
3. Bottom section
4. Guide rails
5. Control cabinet

### 1.1.1 Standard

The ASSA ABLOY VL3116 vertical lifting fabric door is supplied with the following specifications as standard:

Door leaf:	Polyester, 1100 dtex with plasticised PVC coating
Safety:	Safety arresters Optical safety edge
Operation:	Operator + control unit
Colors:	Choice of 8 standard colours

### 1.1.2 Options

ASSA ABLOY Entrance Systems provides a wide range of options and accessories to customise the ASSA ABLOY VL3116 vertical lifting fabric door to any customers needs. For example:

Door leaf:	Heat resistant, sound reduction and security fabrics Vision panels
Guide rails:	Jams for protection and insulation Heating cables
Header box:	Protective cladding
Colors:	Optional colors on request
Operation:	Automation

## 1.2 Door leaf

### 1.2.1 Construction

The door leaf is made of two layers of very strong vinyl-coated polyester fabric, separated by aluminium intermediate sections. The aluminium top section is bolted to the header box, the steel and aluminium bottom section is connected to the lifting belt via the safety arresters.

The fabric is attached to both sides of the intermediate sections, top section and bottom section with self-tapping screws through aluminium clamp strips, providing maximum tightness.

Wind load is transferred to the vertical guide rails by the horizontal aluminium sections of the door leaf.



### 1.2.2 Intermediate section

The intermediate sections give strength to the door leaf and create a buffer between the inside and outside fabric walls. Self-lubricating slide blocks at each end of the intermediate sections run in the guide rails when the door opens and closes.

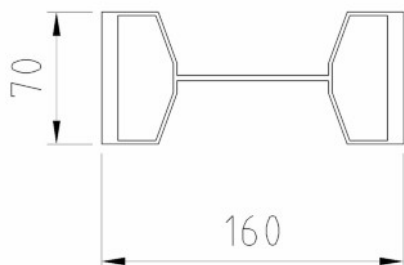

### 1.2.3 Bottom section

The bottom section, made of steel and aluminium, is connected to the lifting belt via the safety arresters. The bottom section contains a safety edge and a rubber seal on the bottom edge that creates a seal between the door and the floor.

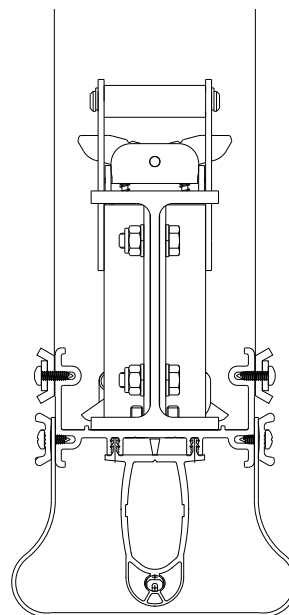

### 1.2.4 Safety arresters

The safety arresters are connected to each end of the bottom section. The lifting belt is connected to the safety arresters.

The safety arresters have four hooks. The two upper hooks operate as a wind lock when the door is closed. The two lower hooks are the safety hooks and grip the guide rails to stop the door if the lifting belt becomes slack or, in an unlikely event, would break.



## 1.2.5 Material

### Standard Fabric

The standard door-leaf fabric is a single sheet of heavy-duty vinyl-coated polyester. The fabric is resistant to mechanical abrasion and sparks generated from mechanical processes such as welding.

The standard fabric is available in 8 standard colours, however other colors are available on request.

### Sound-reduction Fabric

The sound-reduction fabric is for use in environments where the transmission of sound through the door must be reduced. It is installed on both sides of the door leaf behind the standard fabric.

### Heat-resistant Fabric

The heat-resistant fabric replaces the standard fabric on the inside of the door leaf when there is a requirement to contain heat and/or chemical hazards. It is available with three different coatings dependant on the environment where it is going to be used.

### Security Fabric

The security fabric is for use in environments where security is important. It is similar to the standard fabric with the addition of galvanized steel wires inside the fabric. It is installed on both sides of the door leaf behind the standard fabric to a height of about two meters.

### Vision Panels

Vision panels (windows) are available for the standard fabric to improve light admission and visibility through the door leaf. The vision panels are available in four different sizes.









### Insulation

The insulated fabric is for use in environments where thermal loss is important. It is installed on both sides of the door leaf behind the standard fabric.

## 1.2.6 Colors

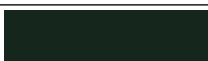
The RAL-colors are as close as possible to the official RAL HR collection.

### 1.2.6.1 Standard colors

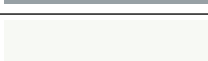
	RAL 1001
	RAL 1003
	RAL 3001
	RAL 5005
	RAL 6009
	RAL 7004
	RAL 7016
	RAL 9006
	RAL 9016

### 1.2.6.2 Optional colors

Other colors are available on request.

## 1.2.7 Options

### Painted clamp strips

Painted clamp strips are available in the same standard colors as the fabric.

The benefits of the painted clamp strip are:

- Improve the appearance of the door leaf
- Protect the door leaf from discoloration in certain environments.

## 1.3 Guide rails

The vertical guide rails are made from extruded aluminium. The lubrication-free slide blocks at each end of the door leaf sections travel through these guide rails.

The guide rails have weather sealing on the inside and outside faces. There is also a space inside the guide rails for the lifting belt of the drive unit and safety arresters.

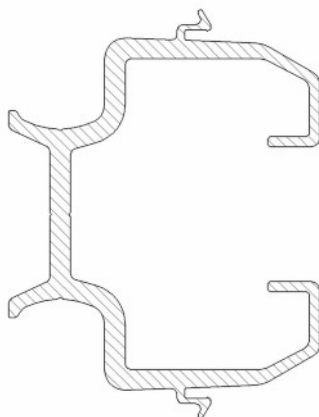

### 1.3.1 Jambs

If posts for installing the guide rails are not available, stable jambs can be provided. These jambs can be installed, against a concrete or steel wall structure, in the same way as the guide rails. It is possible to insulate the jambs, but material for the purpose is not included in the delivery. The jambs are made of steel painted black.

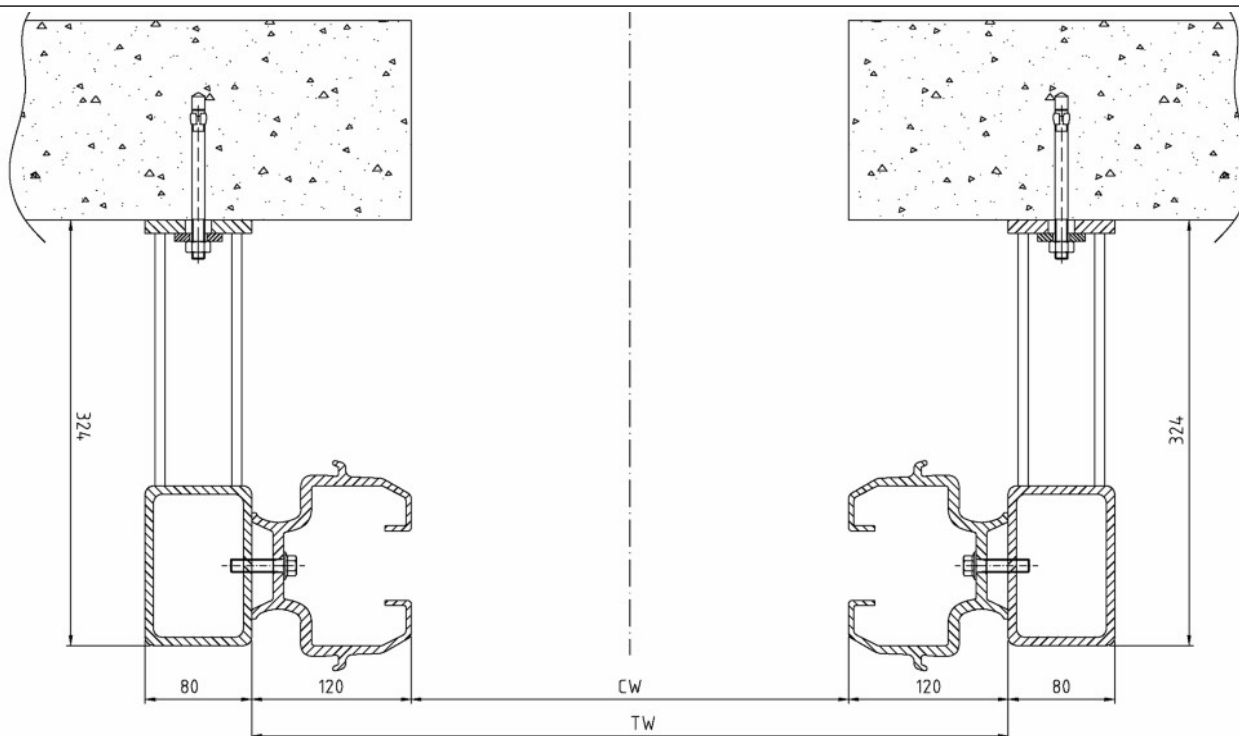

### 1.3.2 Wind deflectors

Used with jambs to avoid strong side winds, pressing sand or snow inside the door leaf.

---

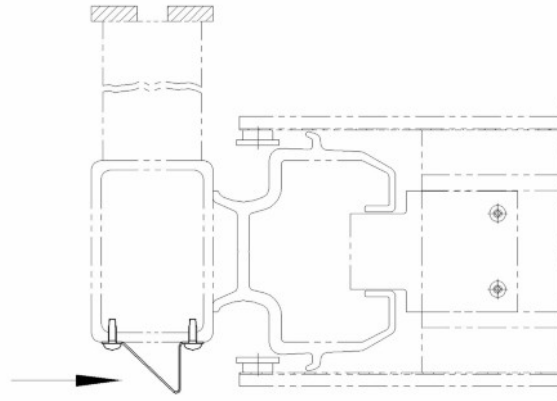

## 1.4 Header box

The header box contains the gear motor, the belt drum, lifting belts, pulleys and limit switch boxes. It can be installed with the gear motor on the inside or the outside of the building. As standard, the motor side of the header box is enclosed by powder-coated sheet steel covers. Cover plates allow access to components that need maintenance.

### 1.4.1 Header box options

#### 1.4.1.1 Non-motor side covered

If the header box is positioned in the door opening with the gear motor facing inwards, the non-motor side should be fitted with a cover. An inspection can still be done from the motor side, in this case from inside the building. The header box can be insulated as an option.

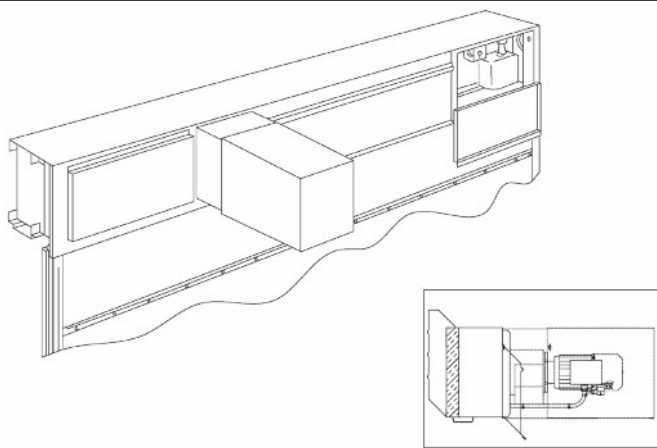

#### 1.4.1.2 Protective casing for motor

In corrosive or dirty environments, the motor should be fully protected. The protective casing is made of powder-coated sheet steel. The casing has a hatch to facilitate easy access to the motor for emergency operation. The casing is detachable. Existing doors can also be equipped with a protective casing.

#### 1.4.1.3 Stainless steel cladding and motor casing

In corrosive environments, the header box, including the mechanical unit, can be enclosed in stainless steel casing.

#### 1.4.1.4 Limit switch boxes

The limit switch boxes contain inductive proximity switches with high ingress protection level (IP67) and temperature tolerance.

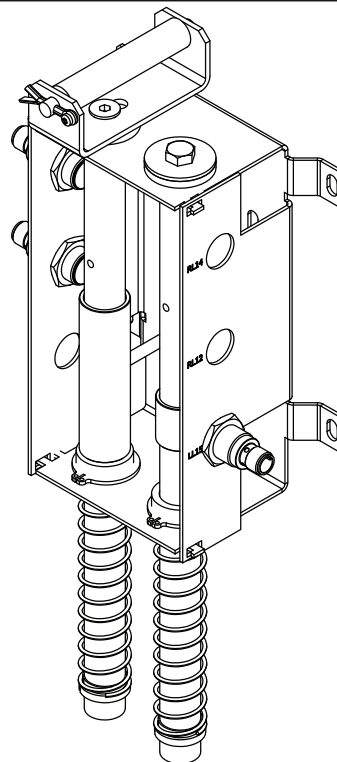

### 1.4.2 Header box - self-supporting version

ASSA ABLOY can supply a self-supporting door if there is no suitable mounting surface over the door opening. A supporting beam underneath the header box transfers the load via the jambs of the door to the building. The jambs take up the forces from the header box, but must be secured to the building.

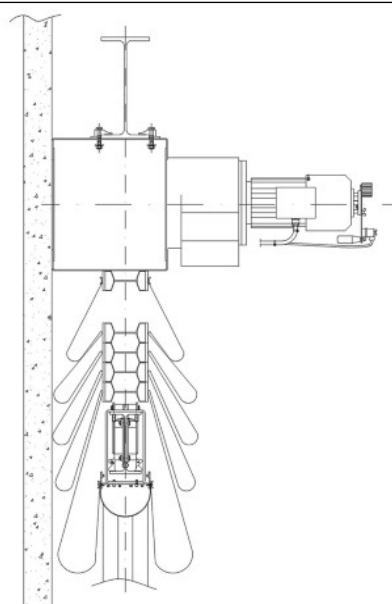

## 1.5 Operating system

### 1.5.1 Electrical operation

The ASSA ABLOY VL3116 vertical lifting fabric door is always supplied with an electrical operating system, a control unit near the door and a gear motor in the header box.

The door is opened by an impulse from the UP-button or from an optional device, such as a radar or magnetic loop.

The door is closed by an impulse from the DOWN-button or by an optional device.

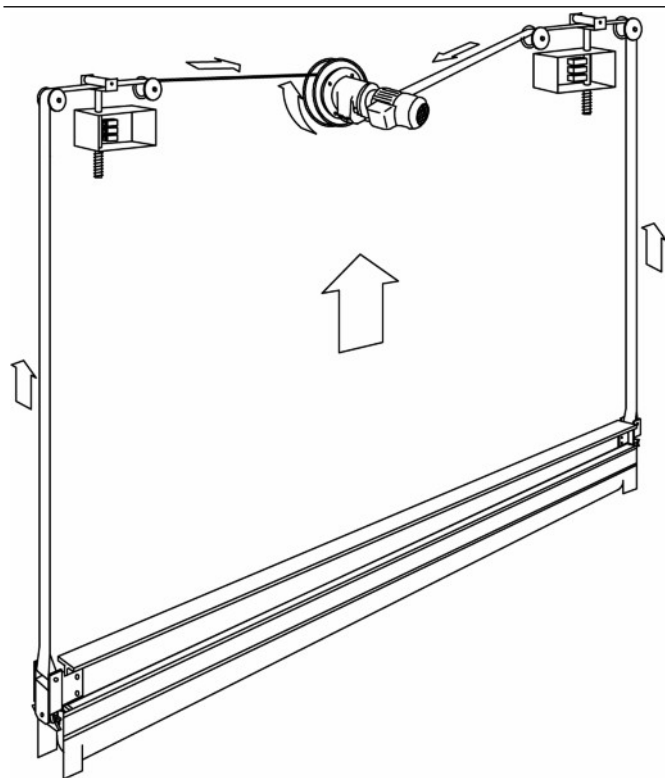

### 1.5.2 Belt system

The belt system consists of one lifting belt that can withstand corrosion, dust and dirt. This belt is connected to the safety arresters at both ends of the bottom section, through the guide rails, up to the belt drum. The belt drum is installed on the output shaft of a braked reduction-gear motor by a keyed joint.

### 1.5.3 Gear motor

The gear motor is suited for the actual weight of the door leaf. The electric gear motor winds the belt onto a drum.

In the event of a power failure, the door can be manually operated by means of a hand crank connected to the motor.

### 1.5.4 Control unit

The door is supplied with a PLC-based control unit installed near the door. The control unit commands the gear motor via push buttons or via external activators, e.g. a mechanical loop or radar.

The UP and DOWN buttons are operated by impulse. The DOWN button can be set to hold-to-run. The gear motor can be disabled from the control unit for emergency hand-crank operation by switching off the mains.



#### 1.5.4.1 PLC

The control unit contains a PLC for the setting of timers, automatic and safety functions. The PLC is programmed and configured before delivery. The menu gives the following information:

- Number of days of operation and number of door openings from the start since the door was last serviced.
- Current settings
- Diagnostics.

#### 1.5.4.2 Heating element

An optional heating element can be installed in the control unit, to avoid moisture inside the unit at low and variable temperatures and in moist air.

### 1.5.5 Safety edge

The ASSA ABLOY VL3116 vertical lifting fabric door has a safety edge on the bottom of the door. If the door hits an obstacle, the door will stop and return to its original position.

The conductive rubber safety edge has a pre-fitted resistor that is monitored through wires extruded through the length of the rubber. The wires are connected to two separated conductive rubber surfaces.

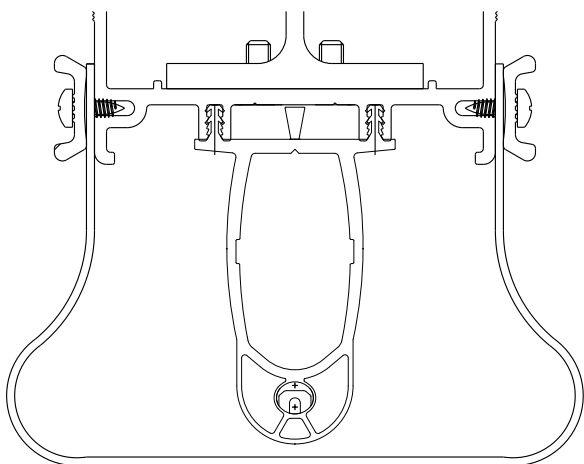

### 1.5.6 Access and automation

ASSA ABLOY offers a wide range of functions that allow advanced opening and safety control.

#### 1.5.6.1 Basic control functions

##### Hold-to-run control

If required, the door can be supplied without safety edge, with closing by hold-to-run control as only alternative.

##### Interlocking

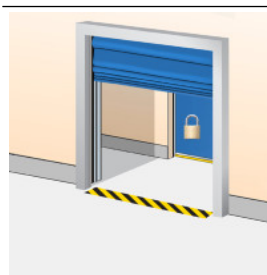

Developed for climate control or safety; if door A is open, door B cannot be opened. If door B is open; door A cannot be opened. Selector switch in control unit.

#### 1.5.6.2 External control functions

##### Pull-rope switch

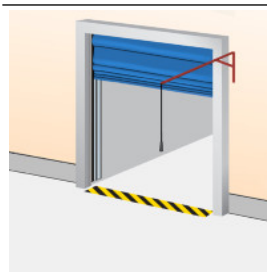

A pull rope switch next to the door opening can be operated from e.g. a forklift truck. Pulling the rope opens a closed door or closes an open door. Installed on the wall, with bracket.

##### External push button box

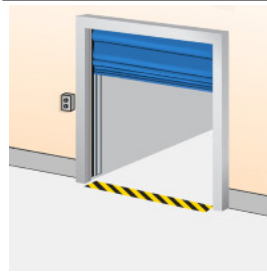

An extra control box is installed outside the building or inside close to the door if the main control unit needs to be installed away from the door opening. Installed on the inside or outside wall beside the door.

### Remote control



A hand-held radio transmitter allows door operation from a vehicle or any position within 50-100 meters from the receiver and aerial at the door. For closing, the door can be provided with a photocell beam. Receiver installed in control unit, antenna installed on the wall beside the door.

### 1.5.6.3 Automatic control functions

#### Magnetic loop



A sensor in the floor detects a metal object (usually forklift trucks, pallet trucks) and opens the door automatically. This is an ideal solution for frequent vehicle traffic. Installed on the outside, inside or both sides of the door in the ground.

#### Radar

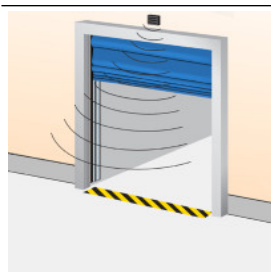

An infrared sensor above the door detects an object (person, vehicle) within a specified distance from the door and opens the door automatically. This is an ideal solution for frequent vehicle or personal traffic. Often combined with automatic closing. Installed on the inside or outside wall above the door.

#### Automatic closing

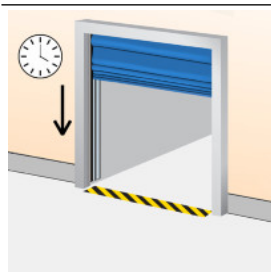

A programmable timer that closes the door after a specified time, counted from either the fully open position and/or from passing through the photocell beam. Selector switch in control unit.

### Automatic opening and closing

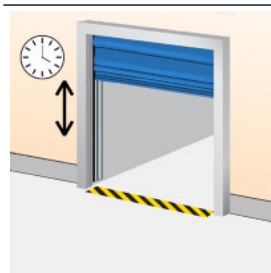

A programmable timer that closes the door after a specified time, counted from either the fully open position and/or from passing the photocell beam. A sensor, e.g. a magnetic loop or a radar, is used for automatic opening. Selector switch in control box and magnetic loop or radar.

### 1.5.6.4 Safety functions

#### Safety photocells 1-channel

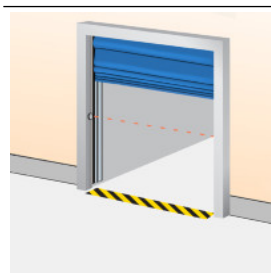

A set of a photocell transmitter with reflector or receiver is installed in the door opening. If the photocell beam is interrupted during closing, the door will stop in less than 30mm and reverse to the fully open position. Installed in the door opening.

#### Safety photocells 2-channel

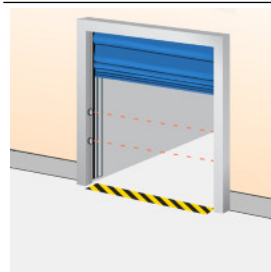

Two sets of photocell transmitters with reflectors and receivers are installed in the door opening. If one or both photocell beams are interrupted during closing, the door will stop in less than 30mm and reverse to the fully open position. Installed in the door opening.

#### Warning lights - Red

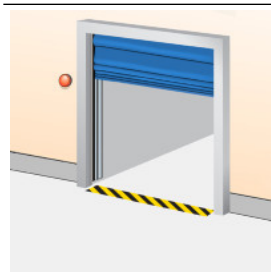

One or two red warning lights indicating that the door is moving or closed; continuous light when the door is closed, flashing light when the door is moving or not fully open. Installed on the inside and/or outside wall beside the door.

### Warning lights - Green

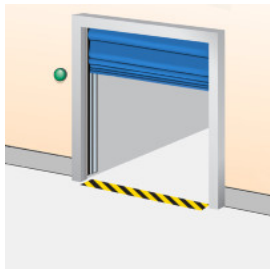

One or two green warning lights indicating the open position of the door by continuous light signal. Installed on the inside and/or outside wall beside the door.

### Warning lights - Orange flashing lights

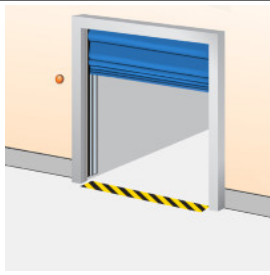

Flashing light during door movement. Optional; Flashing lights during an adjustable time period before automatic closing. Automatic closing required. Installed on the inside and-or outside wall beside the door.

### Emergency power switch

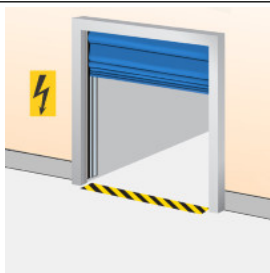

An external power switch can be enabled, as a backup system, in case of a power failure. Supplied with steel casing and power inlet socket.

#### 1.5.6.5 Additional functions

##### Increased opening speed

Smaller OH1042S overhead sectional doors can be equipped with an optional motor that doubles the opening speed to 0.4 - 0.6 m/s.

## 2 Specifications

### 2.1 Clear width and clear height

The standard ASSA ABLOY VL3116 vertical lifting fabric door is delivered in the following size range:

Standard door sizes*		
	Clear width	Clear height
Min.:	5760 mm	
Max.:	14000 mm	16000 mm

\* Other sizes may be available on request

### 2.2 Environmental tolerance

Heat and cold resistance	-35°C to +70°C
Atmospheric humidity	below dew point
Presence of particles	< 1000 mg/m <sup>3</sup> air
Mechanical load, blasting	Not directly aimed.
Wind speed, in motion	< 20 m/s
Acidity	Condensate at 5<pH<9
Explosive fumes or dust	No occurrence.

\*In the normal version, the door is suited for operation in environments within the limits stated above. If the requirements exceed these limits (e.g. wind load), the door can often be modified on request.

### 2.3 Surface treatment

Steel components	For corrosion, category 3 according to ISO 12944.2. Higher class on request.
Other parts	Aluminium, plastic, stainless steel, zinc electroplated steel (~ 10m). Fixing elements are zinc electroplated (~ 10 m).
	Door leaf screws are corrosion protected with Geomet.

## 2.4 Door leaf

### 2.4.1 Fabric data

#### 2.4.1.1 Standard fabric

Application	Standard		
Use	Standard		
Coating	Plasticized PVC		
Fabric	Polyester, 1100 dtex		
Weight	700 g/m <sup>2</sup>		
Heat- and cold resistance	-35°C to +70°C. DIN EN 1876-2 1998-01		
Tensile strength	Warp : 2500N/5 cm acc. DIN 53354, EN ISO 1421 Weft : 2000N/5 cm acc. DIN 53354, EN ISO 1421		
Tear resistance	Warp : 400N acc. DIN 53363 Weft : 300N acc. DIN 53363		
Resistance to light	7 - 8 (on a scale 0-8). ISO 105-B02 1998		
UV-stabilized	Yes		
Fire classification	M2 (NF P 92 507 2004), B - s2,d0 (EN 13501-1 2007)		
Mildew resistant	Yes		
Rot resistant	Yes		
Radar reflection	0.3 dB, - 0.1%		
Lacquered	Yes		
Standard colors	<ul style="list-style-type: none"> <li>• Beige</li> <li>• Red</li> <li>• Blue</li> <li>• Green</li> <li>• Grey</li> <li>• Anthracite grey</li> <li>• White</li> <li>• White aluminium</li> </ul>	<ul style="list-style-type: none"> <li>NCS 2010Y-40R</li> <li>NCS 2070-R</li> <li>NCS S3560-R80B</li> <li>NCS 8010-G10Y</li> <li>NCS 3500</li> <li>NCS 8005-B20G</li> <li>NCS 0500</li> </ul>	<ul style="list-style-type: none"> <li>RAL 1001</li> <li>RAL 3001</li> <li>RAL 5005</li> <li>RAL 6009</li> <li>RAL 7004</li> <li>RAL 7016</li> <li>RAL 9016</li> <li>RAL 9006</li> </ul>
Logotype	Optional		
Vision panels	Optional		

#### 2.4.1.2 Sound reduction fabric

Application	Sound reduction
Use	On both sides of the door behind the standard fabric
Coating	Plasticized PVC
Fabric	Polyester, 1100 dtex
Weight	1850 g/m <sup>2</sup>
Sound reduction (incl. standard fabric)	Index Rw23dB*, tested by SP Swedish National Testing and research Institute
Heat- and cold resistance	-30°C to +70°C, acc. SFS-EN 1876-1
Tensile strength	Warp: 3000N/5 cm acc. DIN 53354 Weft: 2900N/5 cm acc. DIN 53354
Tear resistance	Warp: 380N acc DIN 53356 Weft: 300N acc. DIN 53356
Fire classification	Acc. SIS 650082, DIN 4102-B1
Comments	Space for fabric folding must be increased by 100 mm on each side of the door, to avoid fabric wear.

Note! Must always be quoted by ASSA ABLOY Entrance Systems.

\* Weighted apparent sound reduction index acc. ISO 717-1. For more information, ask for SP-report P103341, dated 15 June 2001 'Determination of sound insulation of an industrial door according to SS-EN ISO-140-3:95'.

#### 2.4.1.3 Heat resistant fabric - Silicone rubber coating

Application	<ul style="list-style-type: none"> <li>• Hot air environment</li> <li>• Coating highly resistant to chemicals</li> <li>• Good soil and oil repellent properties.</li> </ul>
Use	Replacing standard fabric
Designation	W2643 2 x SIF 80/60
Coating	Silicon rubber on both sides
Fabric	Woven glass fibre EC9-136 acc. to DIN53830-3
Weight	560 g/m <sup>2</sup>
Temperature resistance	+280°C
Tensile strength warp/weft	800 / 600 N / 5 cm acc. to ISO 13934-1
Fire classification	M1 acc. to NF P92-507 ISO 5660-1 IMO Res. A.653 (16) IMO Res. MSC 41 (64) IMO FTP Code, Annex 2, section 2.2
Comments	<ul style="list-style-type: none"> <li>• Never combine standard and heat resistant fabric (for example upper part of the door with standard and lower part of the door with heat resistant fabric).</li> <li>• Protect the bottom sealing with the fabric as well.</li> <li>• When the door is installed against a wall on the cool side, the folding space on the hot side must be increased by at least 100 mm to avoid fabric wear.</li> <li>• The motor should be placed on the cool side. A heat radiation shield below the motor may be necessary.</li> <li>• All cables must be protected.</li> <li>• The clear height should be as large as possible.</li> </ul>

Note! Must always be quoted by ASSA ABLOY Entrance Systems.

#### 2.4.1.4 Heat resistant fabric - Aluminium coating

Application	Hot air and high radiation temperatures inside (e.g. foundries). Good heat reflection properties.
Use	On the inside of the door (never on the outside) replacing standard fabric.
Designation	332 AL-HT
Coating	Aluminium pigments on polyurethane adhesive on one side of the fabric.
Fabric	E-glass EC9-136 (cross twill)
Weight	490 g/m <sup>2</sup>
Heat- and cold resistance	From contact coating +200°C (not continuously)
Tensile strength	Warp : 800N/cm acc. DIN 53857 T1 Weft : 500N/cm acc. DIN 53857 T1
Fire classification	DIN 4102-1 A2
Comments	<ul style="list-style-type: none"> <li>• Never combine standard and heat resistant fabric (for example upper part of the door with standard and lower part of the door with heat resistant fabric).</li> <li>• Protect the bottom sealing with the fabric as well.</li> <li>• When the door is installed against a wall on the cool side, the folding space on the hot side must be increased by at least 100 mm to avoid fabric wear.</li> <li>• The motor should be placed on the cool side. A heat radiation shield below the motor may be necessary.</li> <li>• All cables must be protected.</li> <li>• The clear height should be as large as possible.</li> </ul>

Note! Must always be quoted by ASSA ABLOY Entrance Systems.

#### 2.4.1.5 Heat resistant fabric - Aluminium polyurethane coating

Application	Fire resistant
Use	On the inside of the door (never on the outside) replacing standard fabric.
Designation	W2167 Gp2
Coating	Two sides aluminium grey polyurethane
Thickness	0.8 mm
Fabric	Woven glass fibre, Atlas 1/8
Weight	690 g/m <sup>2</sup>
Heat resistance	+450°C
Tensile strength	Warp : 1350N/cm acc. EN ISO 13934-1 Weft : 1260N/cm acc. EN ISO 13934-1
Fire classification	Incombustible according to M0 (NF P92-507)
Comments	<ul style="list-style-type: none"> <li>• Never combine standard and heat resistant fabric (for example upper part of the door with standard and lower part of the door with heat resistant fabric).</li> <li>• Protect the bottom sealing with the fabric as well.</li> <li>• When the door is installed against a wall on the cool side, the folding space on the hot side must be increased by at least 100 mm to avoid fabric wear.</li> <li>• The motor should be placed on the cool side. A heat radiation shield below the motor may be necessary.</li> <li>• All cables must be protected. The clear height should be as large as possible.</li> </ul>

Note! Must always be quoted by ASSA ABLOY Entrance Systems.

#### 2.4.1.6 Security fabric

Application	Protection against burglary
Use	On both sides of the door, behind the standard fabric. Up to approximately 2 meters from the floor
Designation	Protector PRO
Fabric	PVC coated
Reinforcement	Multi-axial laid construction of galvanized steel wires
Weight	1350 g/m <sup>2</sup>
Heat- and cold resistance	-30°C to +70°C
Fire classification	Not classified
Comments	Space for fabric folding must be increased by 100 mm on each side of the door, to avoid fabric wear.

Note! Must always be quoted by ASSA ABLOY Entrance Systems.

#### 2.4.1.7 Vision panels

Application	Light admission and view through
Use	Only for standard fabric
Standard sizes	Width 800 or 1300 mm, height between the intermediate profiles (depending on door size)
Material	Elaston 064, 1 mm
Weight	1230 g/m <sup>2</sup>
Hardness	77° shore acc. DIN 53505
Heat- and cold resistance	-30°C to +50°C
Tear resistance acc. DIN 53455	Along : 21 N/mm <sup>2</sup> Crosswise : 20 N/mm <sup>2</sup>

#### 2.4.1.8 Insulation

Application	For extra insulated doors
Use	On both sides of the door behind the standard fabric
Designation	CombiTex C-Pro
Material	Polyester fiber, 100% recycled
Weight	400g/m <sup>2</sup> (14mm thickness)
Thermal conductivity	0,032W/mK
U-value (door leaf)*	0,7 – 0,9 W/(m <sup>2</sup> ·K) (EN 12428:2013)
Reaction to fire	B – s1,d0 (EN 13501-1 2007)

Note!

Not in combination with other special fabrics.

Space for fabric folding must be increased by minimum 125mm on each side of the door to avoid fabric wear.

\*U-value depending on model and size.

## 2.5 Operating system

### 2.5.1 General specifications

Control system	PLC-based
Protection class, control cabinet	IP65
Protection class, limit switches	IP65
Protection class, motor brake	IP55
Protection class, push buttons	IP65
Power supply	3/phase 400V 50Hz. Other alternatives available on request
Control voltage	24V AC
Fuse	20 A/ 25 A (depending on drive unit size)
Free contacts	6 for control of user functions
Heat and cold resistance, exterior:	-35 °C to +70 °C
Heat and cold resistance, inside control unit:	-10 °C to +50 °C
Motor ratings	2.8 - 7.4 kW

## 3 CEN Performance

The following tests have been carried out by the Swedish National Testing and Research Institute (SP) in Borås. For more detailed information and values, see ITT report: 0402-CDP-397307.

### 3.1 Lifetime expectation

- 100.000 door cycles

### 3.2 Resistance to wind load

EN12424		
Test result		Class 2-5 (depending on door size).
Class	Pressure Pa (N/m <sup>2</sup> )	Specification
0	-	No performance determined
1	300	
2	450	
3	700	
4	1000	
5	> 1000	Exceptional : Agreement between manufacturer and supplier

### 3.3 Resistance to water penetration

EN12425		
Test result		Class 3 (110 Pa)
Class	Pressure Pa (N/m <sup>2</sup> )	Specification
0	-	No performance determined
1	30	Water spray for 15 minutes
2	50	Water spray for 20 minutes
3	> 50	Exceptional : Agreement between manufacturer and supplier

### 3.4 Air permeability

EN12426	
Test result	
Class 2	
Class	Air permeability dp at a pressure of 50 Pa (m <sup>3</sup> /(m <sup>2</sup> ·h))
0	-
1	24
2	12
3	6
4	3
5	1,5
6	Exceptional : Agreement between manufacturer and supplier

### 3.5 Thermal transmittance

---

**EN12428**

Thermal transmittance                      Depending on door size. Specific data available on request.

---

### 3.6 Acoustic insulation

---

**ISO 717**

Acoustic insulation                              15 dB

---

### 3.7 Operating forces and safe openings

<b>EN12453 &amp; EN12604</b>	<b>Crushing force N</b>	<b>Crushing force N</b>	<b>Crushing force N</b>
Opening gap mm	200 mm from lateral border right from outside	In the middle of the door opening	200 mm from lateral border left from outside
50 mm	passed	passed	passed
300 mm	passed	passed	passed

The crushing force is the force needed for the safety edge to be activated. The maximum force allowed, according to EN12453 safety in use of power operated doors is 400 N within a maximum period of time of 0.75s.

# 4 Building and space requirements

## 4.1 Building preparations

### 4.1.1 Installation of the header box

#### 4.1.1.1 Basic installation

The ASSA ABLOY VL3116 vertical lifting fabric door can be installed in three ways:

1. Installation on internal wall	2. Installation in door opening	3. Installation on external wall
Recommended if the size of the door opening permits it. The drive machinery and guide rails will then be fully protected.	Excellent alternative for an existing door opening. The risk of colliding with the guide rails should be negligible, or a collision shield should be used as protection.	Alternative when the inside environment is severe or when there is insufficient space above the door opening.

#### Side view header box

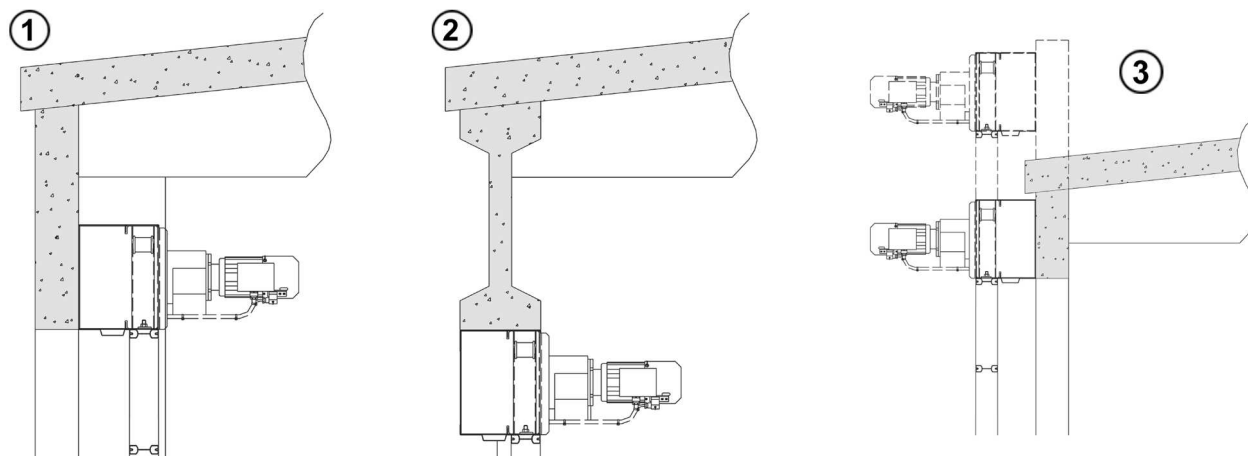

#### Top view guide rail and door leaf

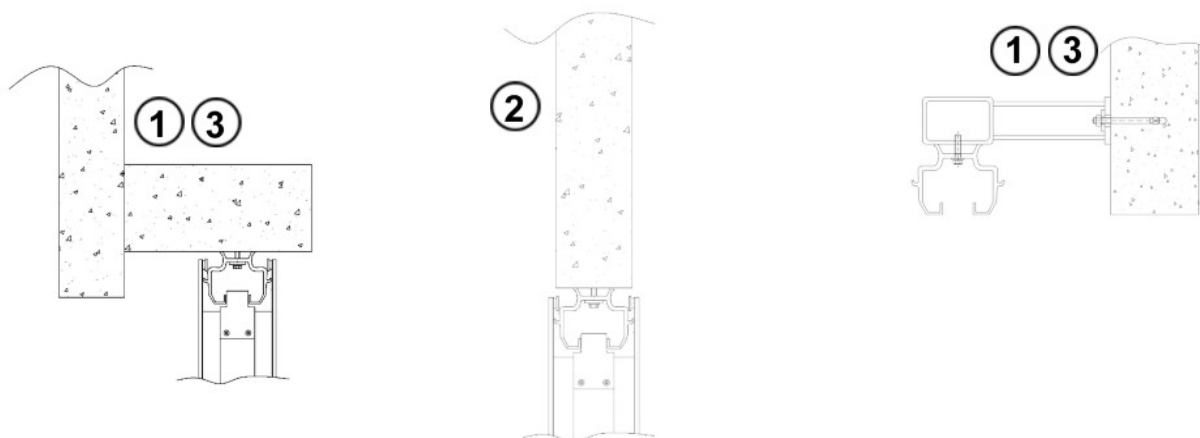

Installation surfaces for the header box must be flat, parallel and deviate maximum 5 mm from a horizontal line.

Min. thickness (t) of installation surface: steel 10 mm, concrete 110 mm. Min. width of each installation surface : 100 mm.

**Installation surfaces – on wall**

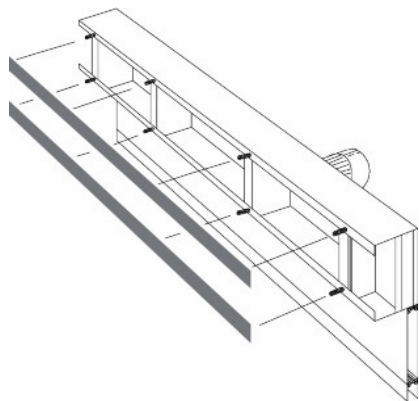

**Installation surfaces – in door opening**

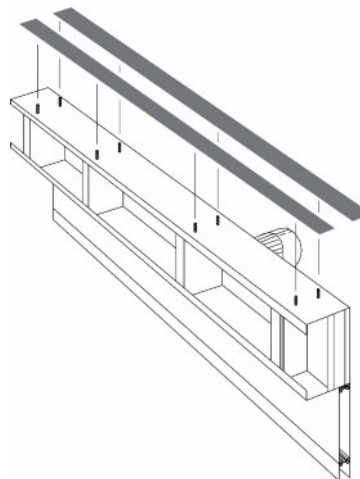

4.1.1.2 Load on the building

**Door closed**

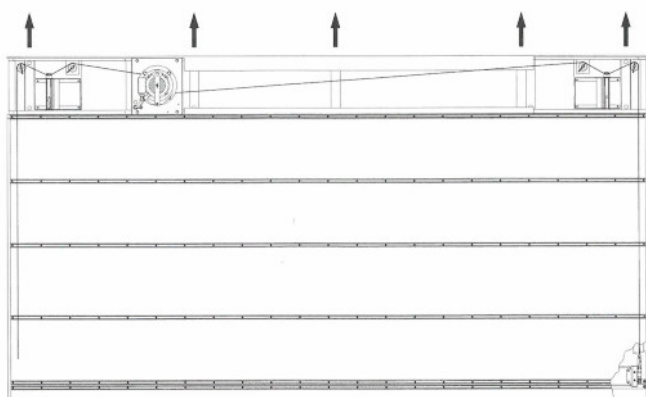

**Door opened**

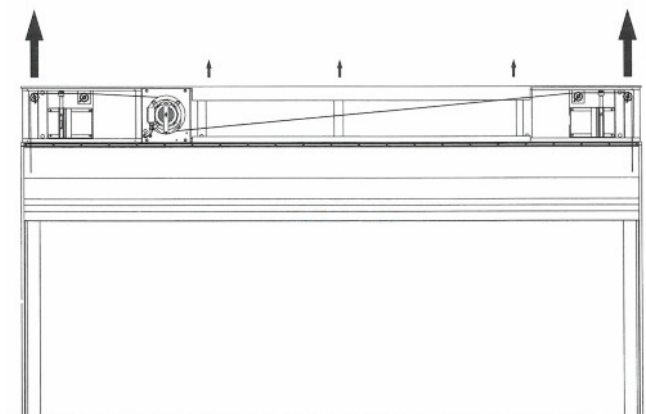

When the door is closed, the total weight is distributed on the fixing points. The distance between fixing points is about 1000 mm. The door leaf itself does not weigh more than 50 to 185 kg per meter width but, in view of the extra load which may result in the event of a collision, the total load of the building should be calculated at 3kN/m.

The load of the door leaf is successively transferred to the ends of the header box as the door is opened. In this situation it is mainly only the weight of the header box that rests on the other fixing points.

#### 4.1.1.3 Self-supporting installation

ASSA ABLOY can supply a self-supporting door if there is no suitable mounting surface over the door opening. A supporting beam above the header box transfers the load via the jambs of the door to the building. The jambs take up the forces from the header box, but must be secured to the building.

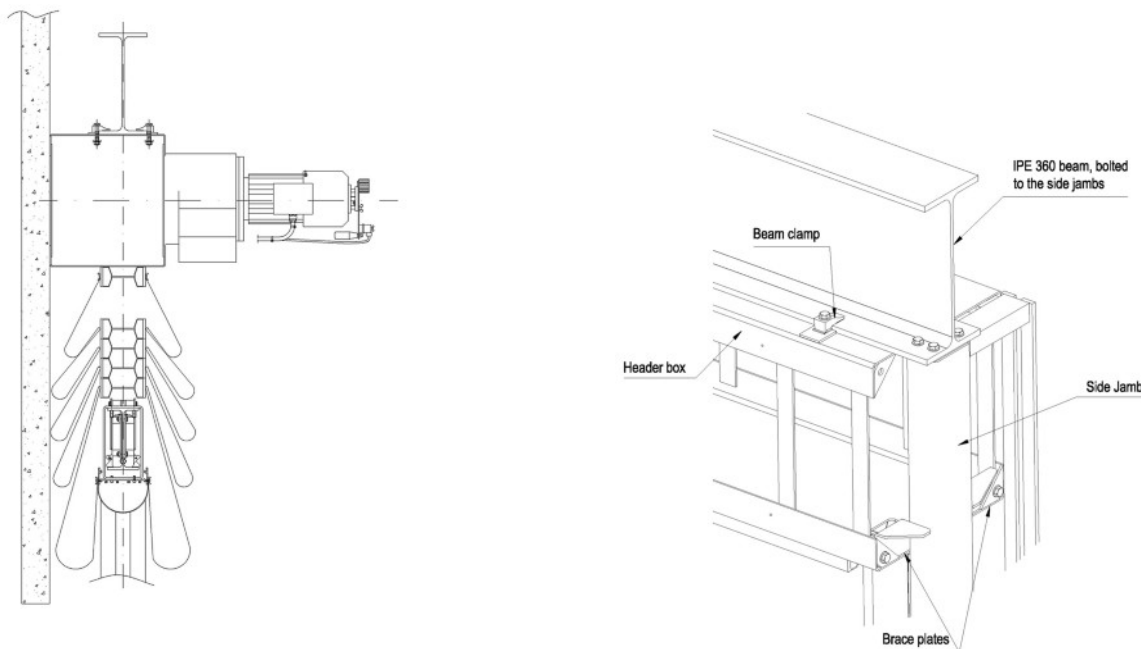

#### 4.1.2 Installation of the guide rails

##### 4.1.2.1 Basic installation

When the door is installed on an existing surface, this surface must be made either from steel or concrete. The installation surfaces must be strong, smooth and parallel and deviate max. 5 mm from the vertical and 2 mm in the inward/outward direction from the vertical.

- Min. thickness of installation surface : steel 8 mm, concrete 100 mm.
- Min. width of installation surface : steel 80 mm, concrete 80 mm.

##### 4.1.2.2 Installation with jambs

When the door is installed on a wall and posts for the installation of the guide rails are not available, jambs of a stable design are provided. The jambs are installed in the same way as the guide rails, by screws or plugs with a spacing of about one meter. The jambs are made of steel painted black.

### 4.1.3 Installation of the control unit

The location of the control unit is best decided as follows :

Environment	Effect on control unit	Location of control unit
Normal environment	Negligible effect, IP65 protection is sufficient.	Close to the door
Harsh interior environment	When opened for maintenance, dust and moisture may enter	In a safe area
Sustainable temperature difference inside/outside	Condensation when door is opened	Away from the door. Push button unit close to the door
Strongly corrosive environment, no safe location possible	Optimum protection required	Stainless steel control unit

Also consider the space requirements of the control unit.

## 4.2 Space requirements

TH	Total height	Distance between floor and top of header box
CH	Clear height	Distance between floor and bottom of door leaf when door is fully opened
OH	Over height	Vertical space required above the clear height
TS	Total space requirement	Distance between outer side of jambs
TW	Total width	Distance between the left and right vertical installation surfaces.
CW	Clear width	Clearance distance between the left and the right guide rails.
MD	Motor depth	Depth of the header box + gear motor + extra space for hand crank
A		Door leaf thickness
B		Minimum free space required for fabric folding
C		Distance from rear side of header box to guide rail centre

#### 4.2.1 Space requirements for operation

In contrast to other types of doors, the ASSA ABLOY VL3116 vertical lifting fabric door requires only limited top and side space. The door leaf is compressed when opened. Even for a large door, the requirements are minimal.

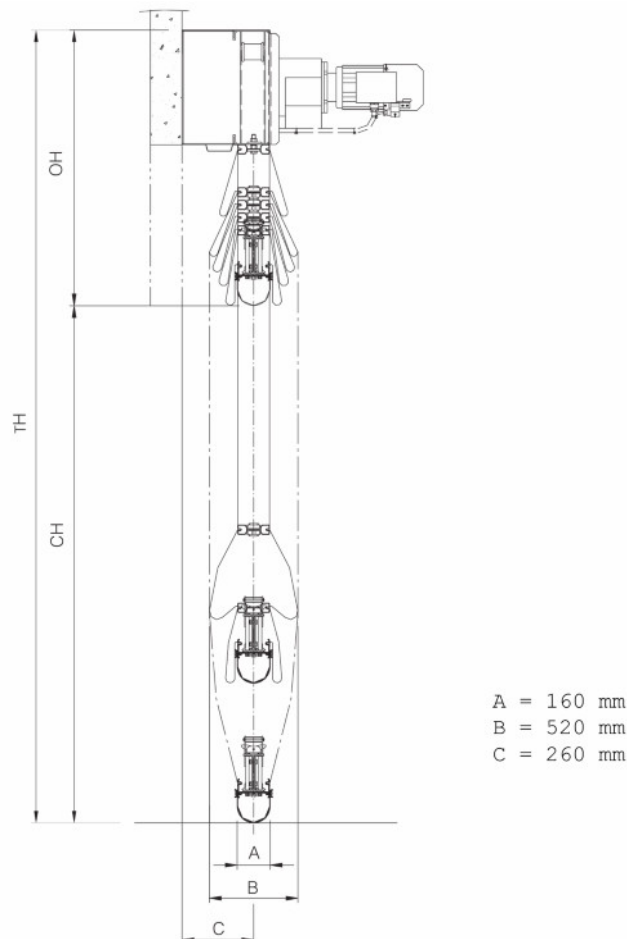

For calculation of actual total height, contact the ASSA ABLOY Entrance Systems representative in your area.

#### 4.2.2 Space requirements for control unit

The following dimensions (w x h x d) may be of assistance in deciding where to place the control cabinet, possible additional cables or an additional safety switch for the power supply :

Control unit size (steel)	500 x 600 x 250 mm
Control unit size (stainless steel)	600 x 600 x 250 mm

#### 4.2.3 Space requirements for maintenance

MD = Motor depth. Depending on motor size.

MD = 1000-1500 mm (+ 200 mm for hand crank).

**Gear motor**

**Limit switches**

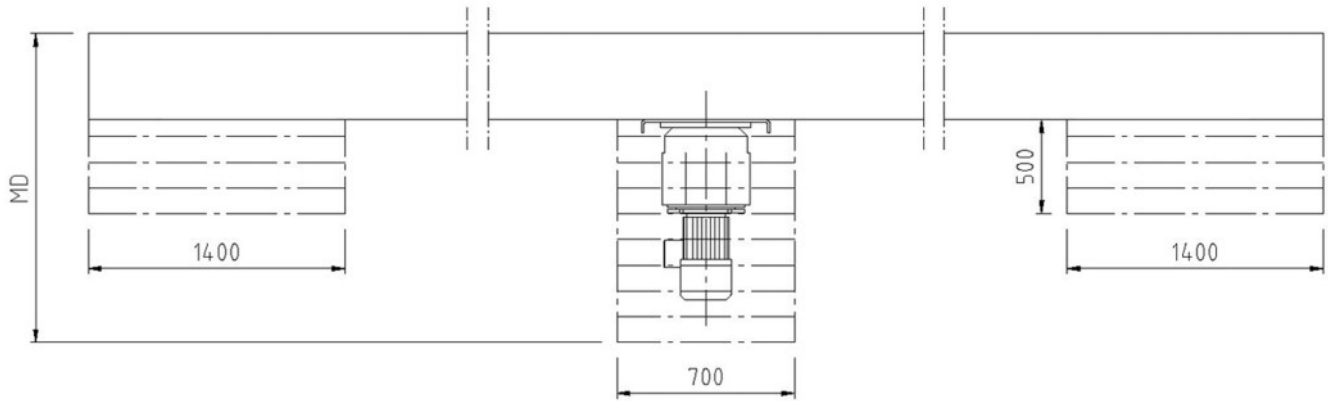

4.2.4 Space requirements - Installation against wall

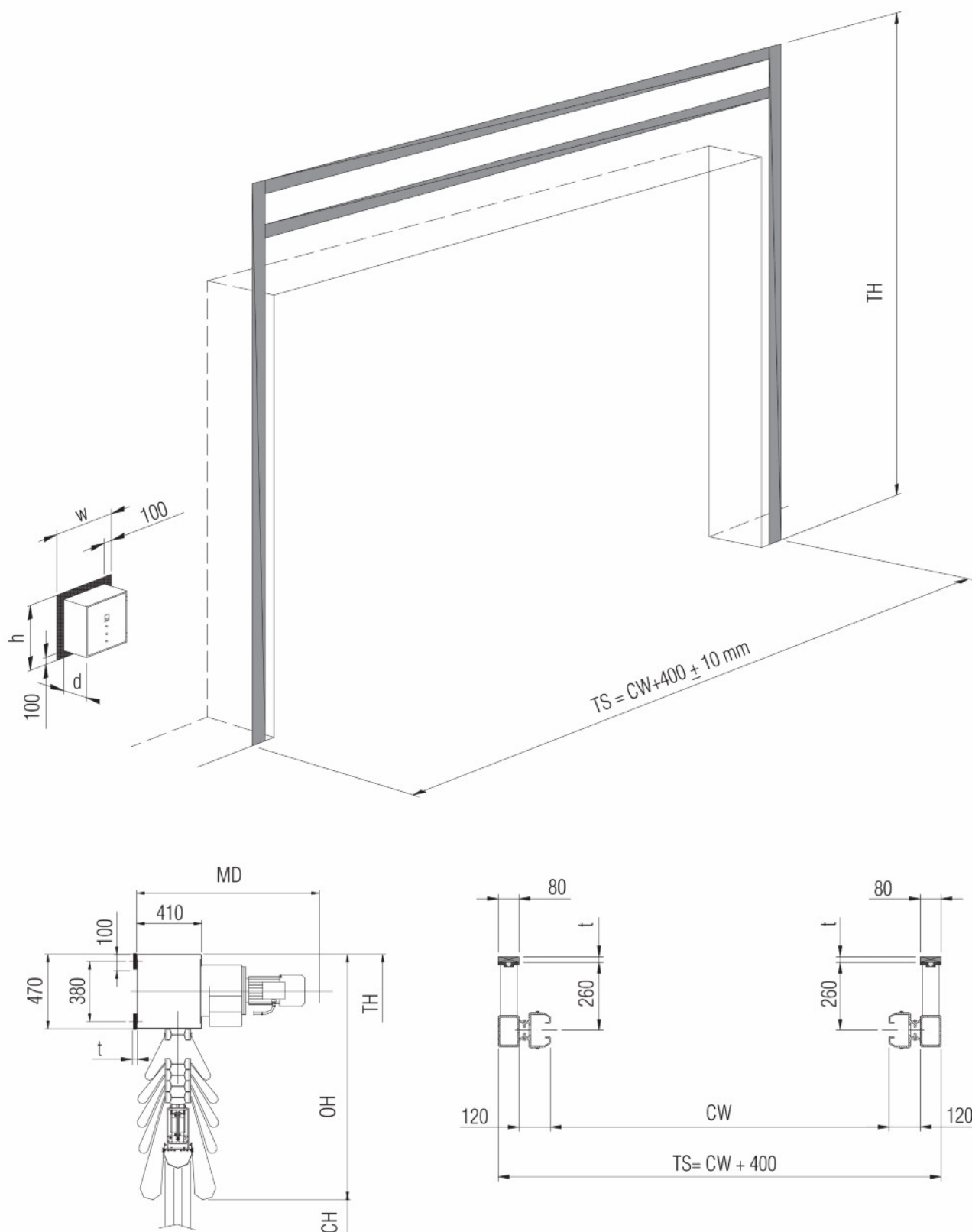

4.2.5 Space requirements - Installation in door opening

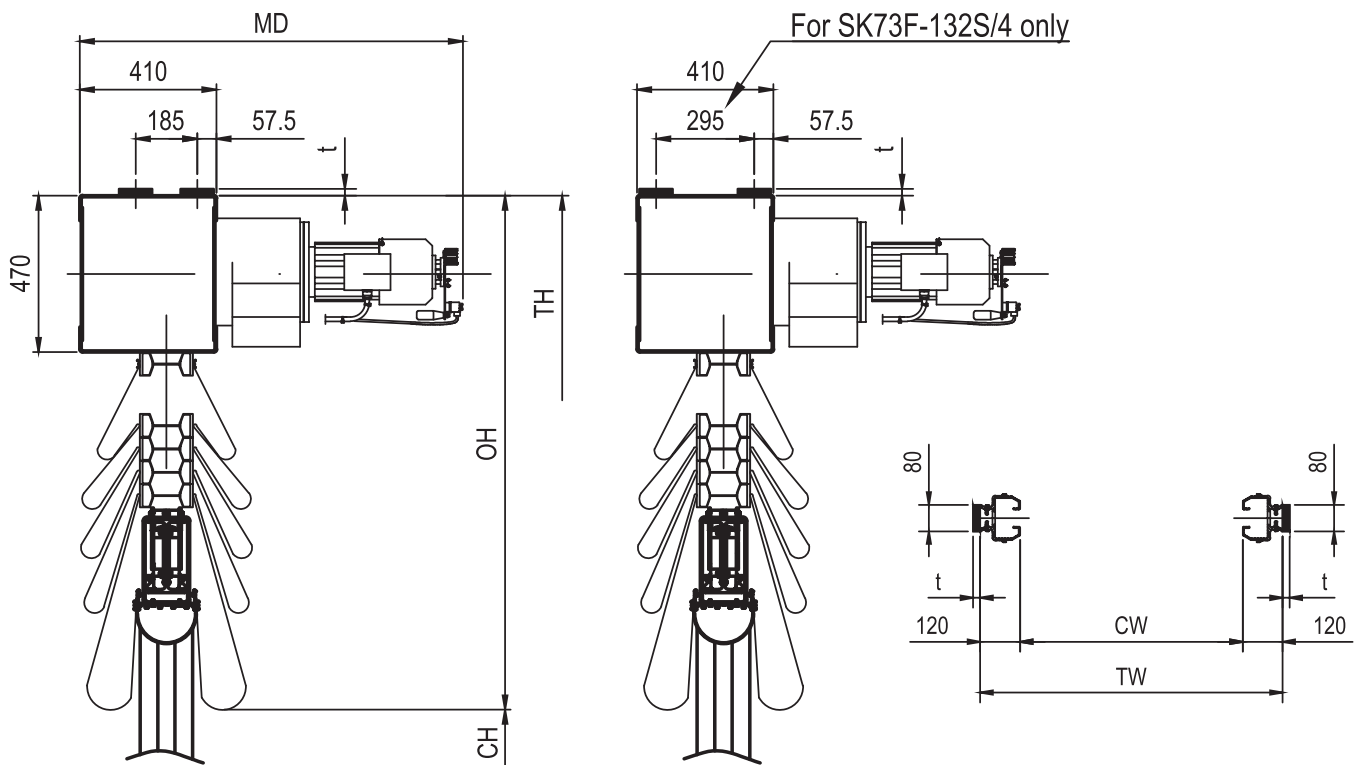
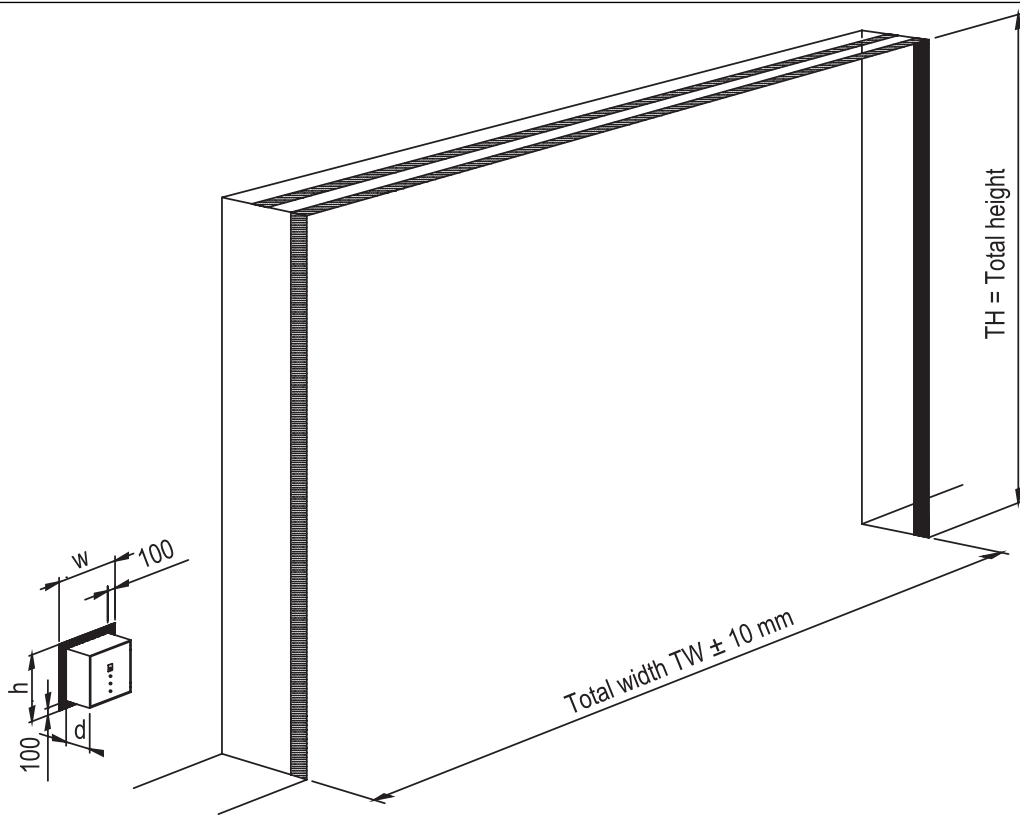

4.2.6 Space requirements - Installation with self-supporting header box

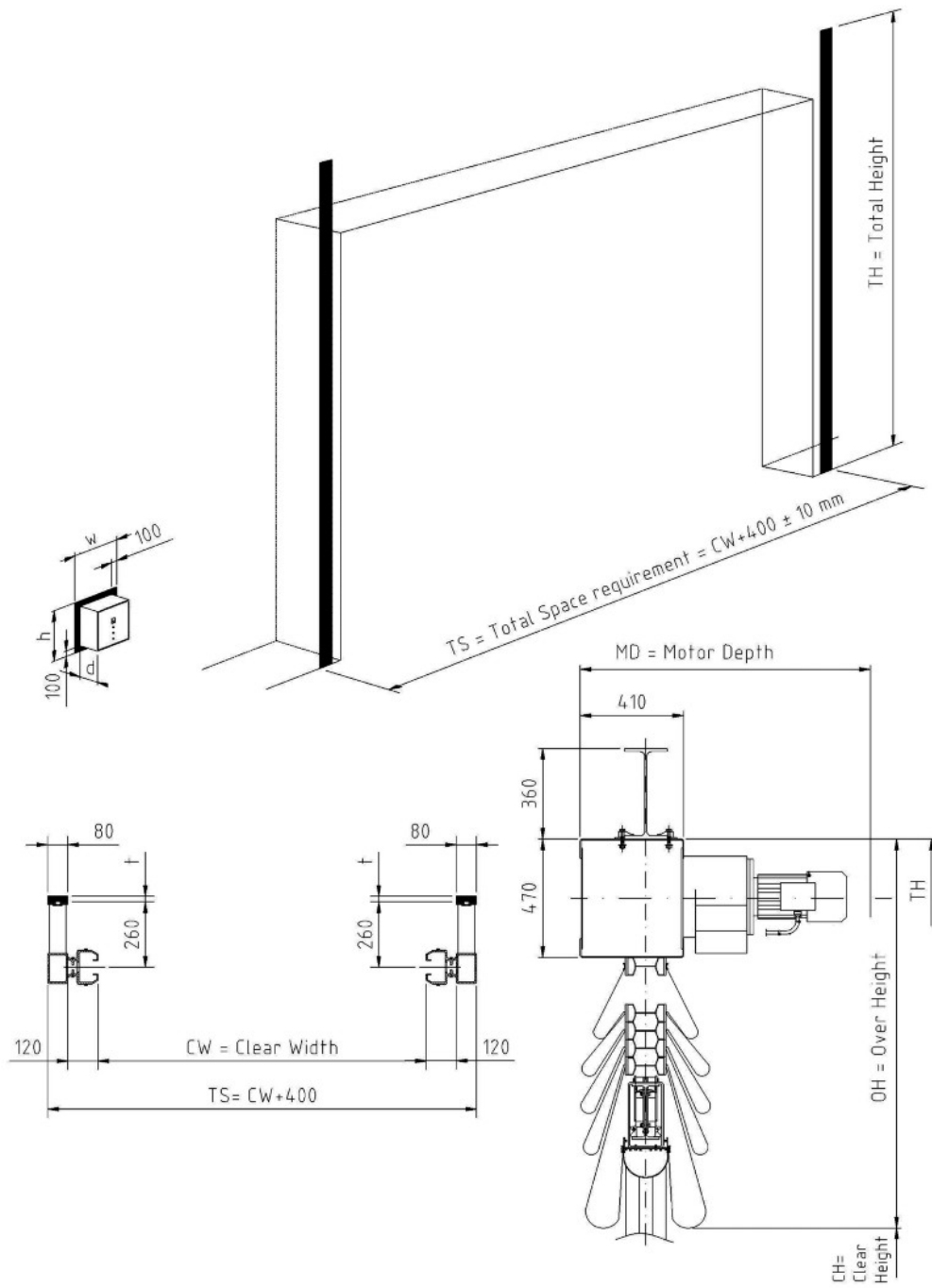

## 5 Service tailored to your needs

Designing and fitting your vertical lifting fabric door is just the beginning. The most meaningful relationships are the ones built to last. We stay by your side long after installation, with service agreements specifically designed to ensure your ASSA ABLOY VL3116 delivers the expected performance you deserve.

To choose the best service agreement for you, we first determine what your priorities are for your vertical lifting fabric door. Just preventive maintenance, or the opportunity to fully optimize its performance? Together, we can tailor your own service agreement to suit you.

**Whatever agreement you choose, one thing is certain – you will always be in good hands and completely taken care of, anytime, anywhere.**



With ASSA ABLOY Maintain you can focus on your core business. We provide preventive maintenance and safety check ups so that your entrance solution always lives up to the latest safety requirements, local regulations and operational guidelines.

You can also choose to have access to our digital connected solutions, which allow you to proactively monitor and control the vertical lifting fabric door and its maintenance requirements.

You can see the status, health and service needs of your ASSA ABLOY VL3116- all in real-time. You can also remotely monitor its performance and get personalized notifications of errors and alerts.



With ASSA ABLOY Optimize, we take full care and responsibility of the equipment, so you will never have to worry about your vertical lifting fabric door.

In addition to the preventive maintenance and safety check-ups offered by ASSA ABLOY Maintain, we also cover all repairs and parts\*, ensuring stable maintenance costs and simplified admin.

It also includes digital solutions that allow us to safely and securely monitor your vertical lifting fabric door and act on the real-time data with planned maintenance or repairs before they become disruptive emergency repairs.

This data also enable us to pinpoint any errors and contact you for remote troubleshooting. If we can avoid sending out a technician, it is cost and time efficient for both parties, and it also helps reduce our carbon footprint.

In cases where we cannot remote troubleshoot, we ensure fast response, sending one of our experienced technicians with the right tools, resources and parts to fix the specific problem - potentially first time.

*\* excluding cases of misuse or collision*

For all your service needs, use our dedicated 24/7 service hotline. From there we can tailor your own service agreement together.

Learn more about ASSA ABLOY Entrance Systems at [www.assaabloyentrance.com](http://www.assaabloyentrance.com).

# Index

## A

Access and automation.....	12
Acoustic insulation.....	22
Additional functions.....	14
Air permeability.....	21
Automatic closing.....	13
Automatic control functions....	13
Automatic opening and closing.	13

## B

Basic control functions.....	12
Basic installation.....	23, 25
Belt system.....	11
Bottom section.....	6
Building and space requirements..	23
Building preparations.....	23

## C

CEN Performance.....	21
Clear width and clear height....	15
Colors.....	7
Construction.....	6
Control unit.....	11
Copyright and Disclaimer Notice.	2

## D

Description.....	5
Door leaf.....	6, 16

## E

Electrical operation.....	11
Emergency power switch.....	14
Environmental tolerance.....	15
External control functions.....	12
External push button box.....	12

## F

Fabric data.....	16
Features.....	3

## G

Gear motor.....	11
General.....	5
General specifications.....	20
Guide rails.....	8

## H

Header box.....	10
Header box - self-supporting version.....	10
Header box options.....	10
Heat resistant fabric - Aluminium coating.....	18
Heat resistant fabric - Aluminium polyurethane coating.....	18
Heat resistant fabric - Silicone rubber coating.....	17
Heating element.....	11
Hold-to-run control.....	12

## I

Increased opening speed.....	14
Installation of the control unit..	26
Installation of the guide rails....	25
Installation of the header box...	23
Installation with jambs.....	25
Insulation.....	19
Interlocking.....	12
Intermediate section.....	6

## J

Jambs.....	8
------------	---

## L

Lifetime expectation.....	21
Limit switch boxes.....	10
Load on the building.....	24

## M

Magnetic loop.....	13
Material.....	7

## N

Non-motor side covered.....	10
-----------------------------	----

## O

Operating forces and safe openings .....	22
Operating system.....	11, 20
Optional colors.....	7
Options.....	7
Options.....	5

## P

Performance.....	3
PLC.....	11
Protective casing for motor.....	10
Pull-rope switch.....	12

## R

Radar.....	13
Remote control.....	13
Resistance to water penetration	21
Resistance to wind load.....	21

## S

Safety arresters.....	6
Safety edge.....	12
Safety functions.....	13
Safety photocells 1-channel....	13
Safety photocells 2-channel....	13
Security fabric.....	19
Self-supporting installation.....	25
Service tailored to your needs..	32
Sound reduction fabric.....	17
Space requirements.....	26
Space requirements - Installation against wall.....	29
Space requirements - Installation in door opening.....	30
Space requirements - Installation with self-supporting header box .....	31
Space requirements for control unit.....	27
Space requirements for maintenance.....	28
Space requirements for operation. .....	27
Specifications.....	15
Stainless steel cladding and motor casing.....	10
Standard.....	5
Standard colors.....	7
Standard fabric.....	16
Surface treatment.....	15

## T

Technical facts.....	3
Thermal transmittance.....	22

V

Vision panels..... 19

W

Warning lights - Green..... 14

Warning lights - Orange flashing  
lights..... 14

Warning lights - Red..... 13

Wind deflectors..... 9



The ASSA ABLOY Group is the global leader in access solutions.  
Every day, we help billions of people to experience a more open world.

**ASSA ABLOY**  
Entrance Systems

ASSA ABLOY Entrance Systems provides solutions for efficient and safe flow of goods and people. Our offering includes a wide range of automated pedestrian, industrial and residential doors, loading dock equipment, perimeter fencing and service.

Follow us:



Please enter ASSA ABLOY Entrance  
in the channel's search field.