

Open to the right  
 Door nr:  
 Quantity:

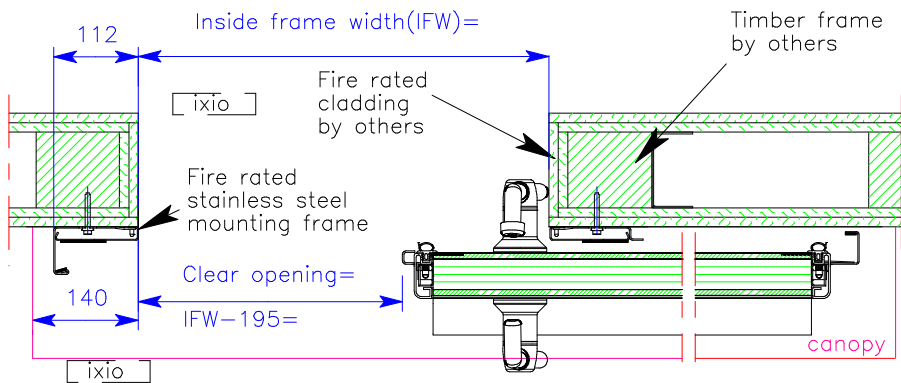

**Remarks:**

- Current:** 230V / 50Hz socket 1P+1N+RA (by others)
- Conduits:** 5/8" conduits for electrical wiring (by others)
- Wiring:** 4 x 0,34 mm<sup>2</sup>, shielded cables, 2m overlength (by others)
- Isolators:** For current, switches and safeties delivered and mounted by others.
- Floor:** -Floor must be level.  
-No corner profile in sliding space

- A:** Switches
- B:** Socket (current)
- C:** Optional functions



Rev.:	Modificatie:	Datum:	Get.:	Checked:
Projektion	Schaal:	Get.: MSc	Project:	
	Maateenheid: mm	Checked:	-	
	Date: 25-04-2024	Project: PR.	-	
On all our designs, drawings and other works belonging to us, our copyright and any other intellectual property rights rest.				
Door type: Medicare E11 30 / 60, Mounting frame E11 automation SDA-05				Size:
Situation: -		Dwg.no.: 40580S4R-214	rev. 00	A4