

Dock leveler

ASSA ABLOY 6011SF-IN

ASSA ABLOY
Entrance Systems

Experience a safer
and more open world



Extra heavy-duty swing lip dock leveler for extreme loads

The DL6011SF-IN is an electro-hydraulic swing lip dock leveler engineered for the most demanding loading environments. With a massive dynamic load capacity of 100 kN (10 tonnes), it provides an exceptionally stable bridge for heavy forklifts and machinery. The platform is reinforced with 10 longitudinal structural members, allowing it to maintain its integrity while naturally twisting to compensate for vehicle tilt during loading.

The DL6011SF-IN offers:

- **High-Capacity Engineering:** Rated for extra heavy-duty cycles with a 100 kN dynamic load capacity as per EN 1398:2009.
- **Superior Durability:** Features a platform constructed from minimum 10/11 mm structural steel tear plate and a 20/21 mm thick swing lip for maximum service life.
- **Optimized Transition:** The orthoscopic swing lip design with tapered edges ensures a smooth, bump-free transition even when loading off-center.

Compliant as per Global standards as below

Complies with relevant machinery directives and safety standards, including:

- Machinery Directive: 2006/42/EC
- Low Voltage Directive: 2014/35/EU
- EMC Directive: 2014/30/EU
- EN ISO 12100:2010
- EN 60204-1:2018
- EN 61000-6-2:2005/AC:2005
- EN 61000-6-4:2007/A1:2011
- EN 1398:2009

Technical Data

Nominal Length	2700, 3000
Nominal Width	2000, 2200
Vertical working range	
Rise above dock	up to 350mm
Fall below dock	down to 300mm
Platform tear-plate thickness	10/11 mm
Max. point load leveller platform	100kN (10 tonnes)
Lip material & length	E250 , 400mm
Lip thickness	20mm
Control unit protection class	IP55
Magnetic valves	Yes
Nominal voltage	24V
Nominal motor power	1.1 KW

Dimensions

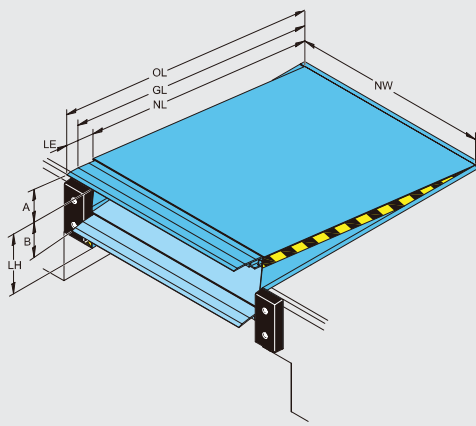

NL	Nominal length
OL	Overall length
GL	Gradient length
NW	Nominal width
LE	Lip extension
LH	Leveler height
A	Working range above dock level
B	Working range below dock level

Dimensions		Vertical working range	
		LE 400	
NL	LH	A	B
2500	600	350	300
3000	600	350	300

Electrical preparations

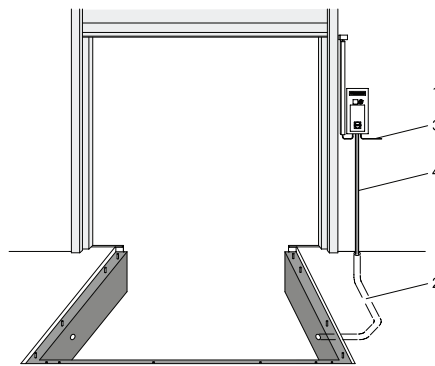

1	Control unit (included in the delivery)
2	Conduit for wiring internal diameter 30, angles <math><45^\circ</math> (Custom)
3	Mains Supply: 3/N/PE AC 50 Hz/400V Motor power: 1,1 kW
4	Motor cable: 7 x 1,5 mm ²

Operating functions for Swing lip levelers



Standard available colours



Blue
RAL 5010



Black
RAL 9005

Technical data subject to change without notice.



ASSA ABLOY Entrance Systems

Website :- www.assaabloyentrance.com/in/en

Contact us: info.in.bsi@assaabloy.com

Company Website